



LMS-16K-A

User Manual

Version: 1.0



Revision Record

Edition	Date	Description
V1.0	2025.8.30	First edition

Legal Provisions

This manual describes in detail the requirements and procedures for safe installation and operation of TIANNENG recharge lithium-ion battery. Please read the manual carefully, only qualified persons are allowed to install, operate and maintain the battery, otherwise it may cause product damage or personal safety risks.

Any actions against safety operations, or do not follow rules of this manual and limited warranty letter, will void warranty and qualification of this product. Meanwhile, the manufacturer will be not responsible for the product damage, property damage, personal injury or even death.

The information contained in this manual is accurate when it's issued. TIANNENG reserves the right to change the user manual (such as optimization, upgrade or other operations) without prior notice, please always view the latest version of user manual via QR code. In addition, please note that the diagrams/schematics in this document are used to help understand system configuration and installation instructions, which may be different from the actual items at the installation.

Manual QR code



Contents

1. Information Overview	5
1.1 Validity	5
1.2 Target group	5
1.3 Content of this document	5
1.4 Definition of symbols	5
1.5 Symbol Description	6
1.6 Terminology and definition	7
2. Safety	8
2.1 Safety precautions	8
2.2 Safety instructions	8
3. Scope of delivery	11
4. Product Overview	12
4.1 Introduction	12
4.2 Features	13
4.3 Specification	13
4.4 Protection function	23
5. Installation	25
5.1 Preparation	25
5.2 Inspection	26
5.3 Installation	27
6. Electrical connection and commissioning	29
6.1 Prepare	29
6.2 Grounding cable connection	29
6.3 Connection block diagram	30
6.4 Communication cable connection	32
6.5 DC power cable connection	33
6.6 Connecting with inverter	34
6.7 Commissioning	35
6.8 Switch off battery	36
7. Troubleshooting and FAQ	37
7.1 Troubleshooting	37
7.2 FAQ	38
8. Transportation and Storage	39
9. Disposal of battery	40
Appendix I	41

1. Information Overview

1.1 Validity

This document is valid for LMS-16K-A movable residential energy storage system.

1.2 Target group





This document is intended for qualified persons and operators. Only qualified persons are allowed to perform the activities marked in this document with a warning symbol and the caption "Qualified person". Qualified persons must have the following skills:
 Knowledge of how lithium iron phosphate batteries work and are operated.
 Knowledge of how an energy storage system (including PV/battery/inverter, MPPT, Meter, Distribution box etc.) works and operates.

Knowledge of local applicable connection requirements, standards, and directives.
 Training in the installation and commissioning of electrical devices, batteries.
 Training in how to deal with the dangers and risks associated with installing, repairing and using electrical devices, batteries.







1.3 Content of this document

This document contains Information Overview, Safety, Scope of delivery, Product Overview, installation, electrical connection & commissioning, Troubleshooting & FAQ, Transportation & storage, Disposal of battery. Please finish reading this document before taking any actions on the battery system.

1.4 Definition of symbols

	Extremely dangerous situation, if not avoided, will result in death or serious injury.
	Dangerous situation, if not avoided, will result in serious injury or property damage.
	Dangerous situation, if not avoided, will result in minor injury or property damage.
	Important or key information, if not avoided, can result in property damage.

1.5 Symbol Description





Label	Definition
	Beware of electric shock.
	Beware of heating.
	Danger!
	The certificate label for European EMC directives
UN38.3	The certificate label for UN38.3 directives
	Recycle label
	WEEE mark. The product must not be disposed of in household waste; dispose of it through environmentally friendly collection centres.
	Indicates activities that can only be performed by qualified persons

1.6 Terminology and definition

Terminology	definition
TIANNENG	Zhejiang tianneng energy storage technology development Co.,Ltd
Battery/battery pack/ battery module	Single recharge battery pack including cells, BMS and enclosure etc.
Battery system/ cluster	Multiple battery pack connected together with power, communication and grounding cables and installation auxiliaries.
BMS	Battery management system
SOC	State of charge
SOH	State of healthy
DOD	Depth of discharge
DIP switch	Dual in-line package switch
COCP	Charge over current protection
DOCP	Discharge over current protection
COVP	Cell over voltage protection
POVP	Pack over voltage protection
CHTP	Charge high temperature protection
DHTP	Discharge high temperature protection
CUVP	Cell under voltage protection
PUVP	Pack under voltage protection
CLTP	Charge high temperature protection
DLTP	Discharge high temperature protection
SCP	Short circuit protection
RCP	Reverse connection protection
FP	Failure protection

2. Safety

2.1 Safety precautions

	<p>Explosion risk</p> <ul style="list-style-type: none"> • Do not impact the battery with heavy objects. • Do not squeeze or pierce the battery pack. • Do not throw the battery pack into the fire.
	<p>Fire risk</p> <ul style="list-style-type: none"> • Do not expose the battery pack to the condition over 80° C. • Do not put the battery near a heat source, such as a fireplace. • Do not expose the battery pack to direct sunlight or raining.
	<p>Electric shock risk</p> <ul style="list-style-type: none"> • Do not allow non-qualified person to disassemble the battery pack. • Do not touch the battery pack with wet hands. • Do not expose the battery pack to moisture or liquid environment.
	<p>Damage risk</p> <ul style="list-style-type: none"> • Do not short-circuit or reverse connect the battery. • Do not use chargers or charging devices unapproved by the manufacturer to charge the battery. • Do not mix batteries from different manufacturers or different kinds, types or brands.

2.2 Safety instructions

The battery has been designed and tested in accordance with international (such as UL, IEC, UN38.3 etc.) safety requirements. However, due to various factors during the whole lifetime process, TIANNENG cannot guarantee absolute safety, in order to prevent personal injury and property damage and ensure long-term operation of the battery, please do read the below section carefully to operate the battery and handle emergency situations.

2.2.1 Safety gear

It is required to wear the following safety gear when installing and handling the battery pack.



Insulated gloves



Safety Glasses



Safety Shoes

2.2.2 Emergency safety measures

① Firefighting Measures

The battery modules may catch fire when it is put into the fire. In case of a fire, please make sure that an ABC or carbon dioxide extinguisher is nearby. Water cannot be used to extinguish the fire.

Full protective clothing and self-contained breathing apparatus are required for the firefighters to extinguish the fire.

② Water invasion

Please cut off the AC power supply of the system first and then disconnect all switched under the premise of ensuring safety.

③ Electrolyte or gas leakage

If the battery pack leaks electrolyte, avoid contact with the leaking liquid or gas. If one is exposed to the leaked substance, immediately perform the actions described below.

- Gas Inhalation: Evacuate the people in the contaminated area and seek medical aid immediately.
- Eye Contact: Flush your eye with clean and flowing water for 15 mins and seek medical aid immediately.
- Skin Contact: Thoroughly rinse the exposed area with soap and water to be sure no chemical or soap is left on them and seek medical aid immediately.
- Ingestion: Induce vomiting and seek medical help immediately.

A white warning triangle icon with a black exclamation mark inside, set against an orange background.**WARNING**





In case of fire, please use carbon dioxide fire extinguisher rather than liquid to put out fires.

2.2.3 Other Tips

- All the product are strictly inspected before shipment, please contact your supplier for replacement if you notice there's any defectives such as swelling.
- Do not disassemble batteries and components, otherwise the manufacturer will not be responsible for any damage caused by unauthorized disassembly or repair.
- Do enable the battery to be safely grounded before use to make sure the system in safe and normal operation.
- Please ensure that the electric parameters of these devices are compatible mutually before connecting the battery to other devices.
- Please take the environmental factors into careful considerations to ensure that the system can work in a suitable condition as the environment and storage methods have a certain impact on the service life and reliability of this product.

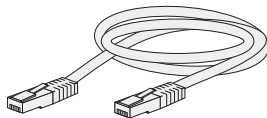
3. Scope of delivery

Check the scope of delivery for completeness and any externally visible damage. Contact your supplier for supplementary delivery if the listed material is incomplete or damaged.

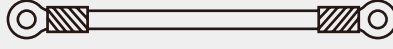
No.	Part name	Detail	Qty.
General part			
1	Battery module	 LMS-16K-A/51.2V314Ah	1
2	Communication cable	 RJ45/CAT6/L=1500mm	1
3	Grounding cable	 AWG10#/yellowgreen/OT6-5/L=1500mm	1
4	Qualified Certificate		1
Optional part			
5	Positive power cable	 1/0AWG /red/SC50-8/L=1500mm	1
6	Negative power cable	 1/0AWG /black/SC50-8/L=1500mm	1

4. Product Overview

4.1 Introduction

The LMS-16K-A Low Voltage Movable Residential Energy Storage System offers 16 kWh capacity with high-energy density 314Ah LFP cells. Its movable design allows for easy movement and maintenance, while it has a better space-efficient, making it ideal for residential use. It is a 51.2V lithium battery system which integrated BMS inside. It could be operated in both on-grid, back-up and off-grid modes with compatible inverters. Below is the general schematic of an ac-coupled system with the batteries.

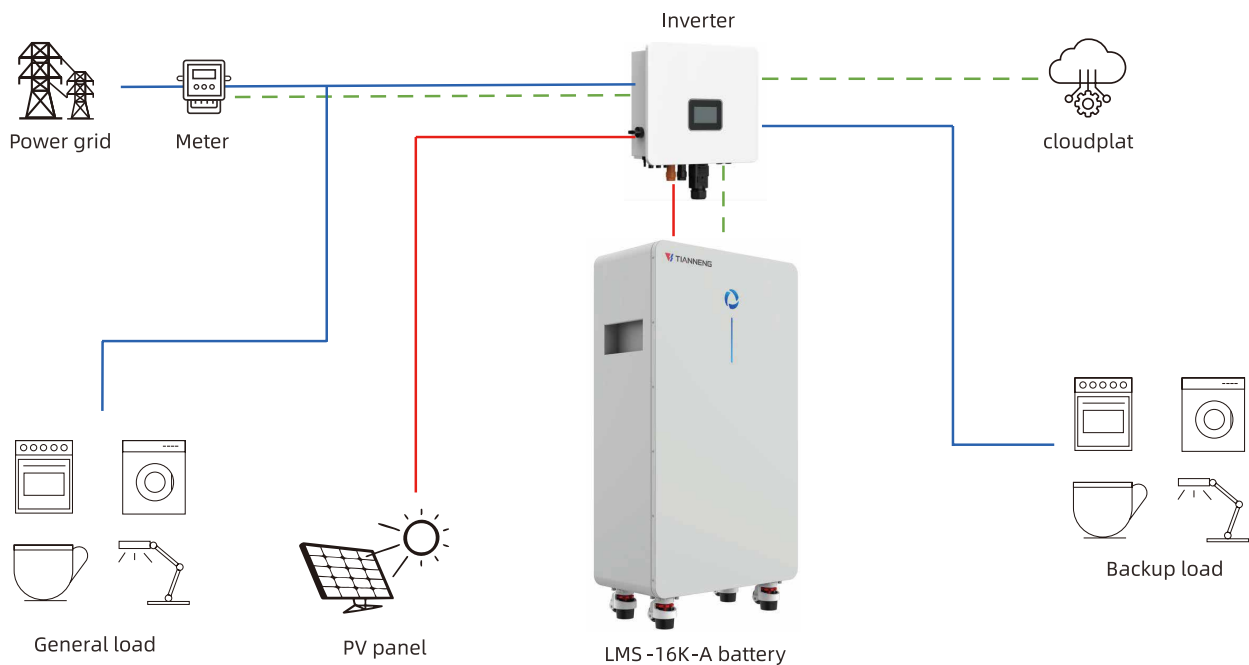

Diagram 4-1 Residential ESS Electrical Schematic Diagram

CAUTION

This electrical connection in this diagram is only for illustration, please follow the Manual suggestions of related devices and operate in accordance with locally applicable connection requirements, standards, and directives.

4.2 Features

- Used the 314Ah LiFePO4 lithium-ion cell, high-energy density, high safety, comply with international safety and transport standard.
- Movable design make it easy to movement and maintenance.
- Modular and flexible, support up to 16 batteries connect together to expand the system energy.
- Built-in pre-charge circuit to avoid surge current when charging.
- Support a maximum of 95% DOD under off-grid and back-up application
- Built in BMS provide warning and protection functions including over-discharged, over-charged, over-current, short-circuit and high/low temperature.
- Supporting automatic balancing function make it upto 6000 cycles lifespan
- Adjustable machine foot for different installation and operating application .
- The simple and elegant LED lighting design makes the product have a style of household appliances .
- Supporting CAN/RS485/RS232 multiple type interface for external communication and BMS upgrade.

4.3 Specification

4.3.1 Dimension

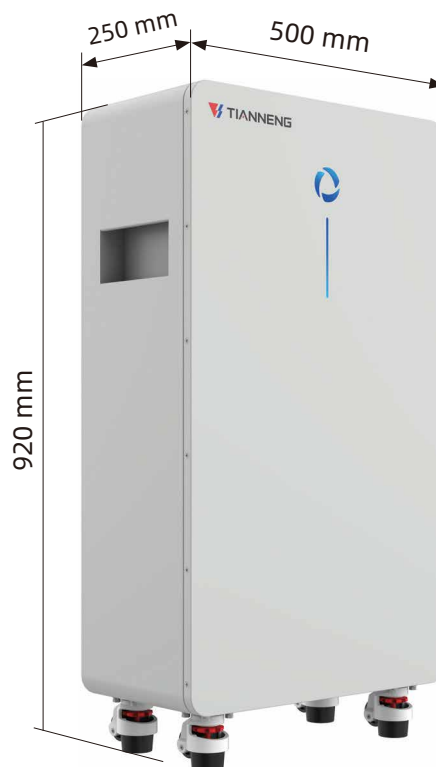

Diagram 4-2 Appearance & Dimension Diagram

4.3.2 Parameters

Table 4-1 LMS-16K-A datasheet

Item	Parameters
Cell model	LFP 3.2V 314Ah
Combination mode	1P16S
Rated energy	16.07KWh
Useable energy	15.27kWh
Rated capacity	314Ah @0.5C@25°C
Rated voltage	51.2V
Voltage range	43.2~57.6V
Rated charge/discharge current	157A
Max charge/discharge current	200A
Cycle life	≥ 6000 cycles @70%EOL@80%DOD@0.5C/0.5C@25°C
Operation temperature range	Charge: 0~55°C Discharge: -20~55°C
Storage conditions	≤ 3months @-20~45°C ≤ 6 months @0~35°C
Relative humidity	5-95%
Altitude	≤ 4000m
Protection grade	IP20
Installation mode	Floor mounted
Fire fighting (optional)	Aerosol
Max. parallel numbers of PACK	16
Communication	CAN / RS485 / RS232
Dimension (W*D*H,mm)	500*250*920, ±2
Weight	128±2kg
Certification	CE / UN38.3

NOTICE

The optimum operating temperature range is from 15° C to 30° C, Frequent exposure to the harsh temperatures may worsen the performance of the battery pack and cycle life.

4.3.3 Panel Interface

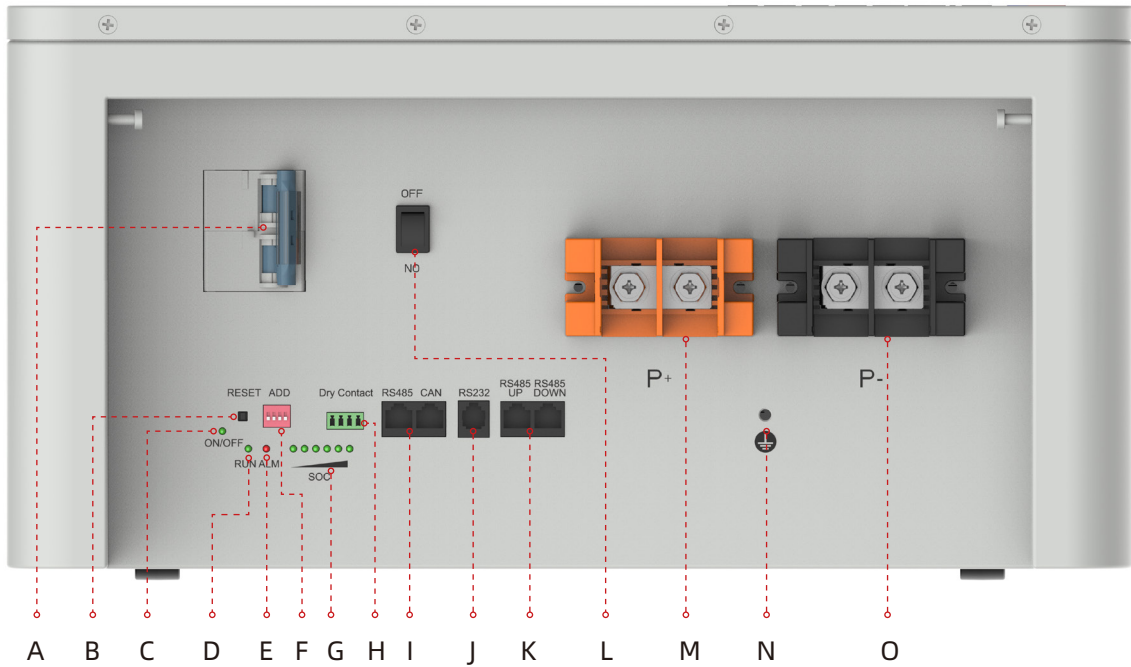

Table 4-2 Panel Interface Descriptions

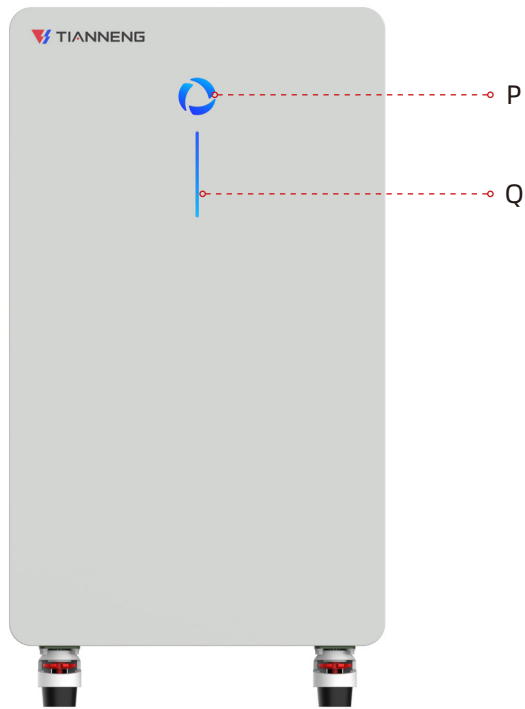

Diagram 4-3 Panel Interface Diagram

Table 4-1 LMS-16K-A datasheet

No.	Items	Description	Remark
A	MCB	Used to power on or cutoff the battery PACK circuit	
B	Reset button	Used to sleep/awake/reset BMS	
C	On/off indicator	Used to indicate the battery power on/off state	
D	RUN indicator 1	Used to indicate battery running status	
E	ALM indicator	Used to indicate battery Alarm/Protection status	
F	ADD	Used to select the BMS address in case of battery used in parallel	
G	SOC indicator 1	Used to indicate battery real-time SOC	
H	Dry contact	Used to connect the external communication to indicate the battery status	
I	RS485/CAN	Used to communicate with inverter via RS485/CANport	
J	RS232	Used to connect to the BMS host computer to upgrade, test or modify the setting, etc.	
K	RS485 UP /RS485 DOWN	Used to communicate between the batteries which in parallel	
L	ON/OFF button	Used to power on & off the BMS	
M	P+	Battery pack output positive terminal, 2pcs	
N	Grounding stud	Used to connect battery with ground	
O	P-	Battery pack output negative terminal, 2pcs	
P	RUN indicator 2	Used to indicate the battery charging/discharging/ alarm etc. status	
Q	SOC indicator 2	Used to indicate battery real-time SOC	

4.3.3.1 ADD-dip switch

When batteries are used in parallel, the addresses can be set through the dip switch to distinguish different batteries. And the master battery (which connect to the inverter) need set the address to “1” , and other slave battery set to 2~16. The definitions are as below:



Table 4-3 Dip switch address definitions

Address	DIP			
	1#	2#	3#	4#
1	ON	OFF	OFF	OFF
2	OFF	ON	OFF	OFF
3	ON	ON	OFF	OFF
4	OFF	OFF	ON	OFF
5	ON	OFF	ON	OFF
6	OFF	ON	ON	OFF
7	ON	ON	ON	OFF
8	OFF	OFF	OFF	ON
9	ON	OFF	OFF	ON
10	OFF	ON	OFF	ON
11	ON	ON	OFF	ON
12	OFF	OFF	ON	ON
13	ON	OFF	ON	ON
14	OFF	ON	ON	ON
15	ON	ON	ON	ON
16	OFF	OFF	OFF	OFF

4.3.3.2 Dry contact

Table 4-4 Dry Contact Definitions

PIN	Type
1	NO Output1, normal open, closed when there is a failure or protection
2	
3	NO Output2, normal open, closed when there is a low SOC warning
4	

4.3.3.3 RS485/CAN

Used to communicate with inverter, please choose the right port according to the inveter, and choose the right protocol in the BMS host computer. The CAN default baud rate is 500K, RS485 is 9600bps.

The protocol for the compatible inverters are detailed in Appendix I

The definition of pin is as below:

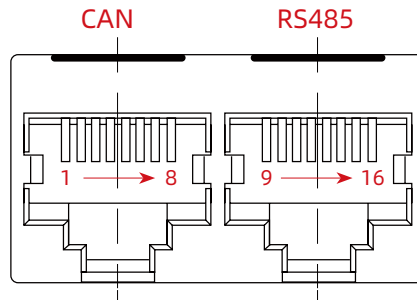

Table 4-5 RS485/CAN Port PIN Definitions

CAN		RS485	
PIN	definition	PIN	definition
1,7,3,6,8	NC	9,16	RS485-B1
5	CANL	10,15	RS485-A1
4	CANH	11,14	GND
2	GND	12,13	NC

4.3.3.4 RS232

The BMS communication to the host computer via the RS232 port, the host computer could able to monitor the realtime data of the battery, such as cell & battery voltage, current, temperature, status, alarm information, etc. and it also could able to review and modify the BMS setting parameter and protection value.

4.3.3.5 RS485 UP & RS485 DOWN

Used to communicate between the batteries which in parallel, the default baud rate is 9600bps.

4.3.3.6 Buzzer

- In case of fault, it will beep for 0.25s per 1s.
- In case of protection, it will beep for 0.25s per 2s (exclude over voltage protection).
- In case of warning, it will beep for 0.25s per 3s (exclude over voltage warning).
- It is set to be off by default at the factory. If you need to enable it, please connect to the host computer to do so.

 **NOTICE**

It is set to be off by default at the factory. If you need to enable it, please connect to the host computer to do so

4.3.3.7 Indicator lighting definitions

Table 4-6 LED Indicator Lighting Definitions

Mode	Status	ON/OFF	RUN1	ALM	SOC 1						RUN2	SOC 2	Description
Power off	-	OFF	OFF	OFF	OFF	OFF	OFF	OFF	OFF	OFF	OFF	OFF	All OFF
Standby	Normal	ON	FLASH1	OFF	Indicate according to battery SOC								Standby mode
	Warning	ON	FLASH1	FLASH3									
Charge	Normal	ON	ON	OFF	Indicate according to battery SOC (highest SOC LED: FLASH2)								Turn to standby mode
	Warning	ON	ON	FLASH3									
	COVP/POVP	ON	ON	OFF	ON	ON	ON	ON	ON	ON			all led ON
	CUTP/COTP/COCP/FP	ON	OFF	ON	OFF	OFF	OFF	OFF	OFF	OFF		OFF	Stop charging
Discharge	Normal	ON	FLASH3	OFF	According to battery SOC								Stop discharging
	Warning	ON	FLASH3	FLASH3									
	CUVP/PUVP	ON	OFF	OFF	OFF	OFF	OFF	OFF	OFF	OFF		OFF	Stop discharging
	DUTP/DOTP/DOCP/FP/RCP/SCP	ON	OFF	ON	OFF	OFF	OFF	OFF	OFF	OFF		OFF	Stop discharging
Failure	Cell/NTC failure Sensor failure MOS failure	OFF	OFF	ON	OFF	OFF	OFF	OFF	OFF	OFF		OFF	Stop charging/ discharging

 NOTICE

'Warning' status including items of cell imbalanced/low voltage/high current/high&low temperature etc.

Table 4-7 SOC 1 and RUN 1 Indicator Lighting Definitions

SOC1 indicator		Charge						Discharge					
SOC1 indicator		●	●	●	●	●	●	●	●	●	●	●	●
RUN 1 indicator ●		ON						FLASH 3					
SOC	0~17%	OFF	OFF	OFF	OFF	OFF	FLASH2	OFF	OFF	OFF	OFF	OFF	ON
	18~33%	OFF	OFF	OFF	OFF	FLASH2	ON	OFF	OFF	OFF	OFF	ON	ON
	34~50%	OFF	OFF	OFF	FLASH2	ON	ON	OFF	OFF	OFF	ON	ON	ON
	51~66%	OFF	OFF	FLASH2	ON	ON	ON	OFF	OFF	ON	ON	ON	ON
	67~83%	OFF	FLASH2	ON	ON	ON	ON	OFF	ON	ON	ON	ON	ON
	84~100%	FLASH2	ON	ON	ON	ON	ON	ON	ON	ON	ON	ON	ON

Table 4-8 LED Flash Definitions

Flash type	ON	OFF
FLASH 1	0.25s	0.375s
FLASH 2	0.5s	0.5s
FLASH 3	0.5s	1.5s
Flash 4	Illuminate sequentially from the lowest to the highest LED, 2s per cycle.	

4.3.3.8 Reset

- When the BMS is in sleep mode, press the reset button for 3~6s and then release it. The BMS will be activated, and the LED indicators will illuminate sequentially for 0.5s, starting from the "RUN" indicator.
- When the BMS is in active mode, pressing the reset button for 3~6s and then releasing it will cause the BMS to enter sleep mode. The LED indicators will illuminate sequentially for 0.5s, starting from the lowest SOC indicator.
- If the BMS is in active mode, pressing the button for 6~10s and then releasing it will trigger a reset of the BMS. All LED indicators will illuminate simultaneously for 1.5s.

 **NOTICE**

Following a reset of the BMS, all setting parameters configured via the host computer will be retained. To restore the system to its factory default settings, the "Restore Default Values" function of the host computer can be used, and the related operation logs and stored data (e.g., battery level, cycle count, and protection records) will remain unaffected.

4.3.3.9 Sleep and active mode

Sleep mode

- Battery will turn to sleep mode when achieved one of below conditions:
- CUVF or PUVF has not been released within 30 seconds.
- Press the reset button for 3~6s and then release it.
- The minimum single-cell voltage is under the sleep voltage. In the absence of communication, protection, equalization, or current, the duration reaches the sleep delay time.
- Standby time exceeds 24hrs in case of there are no communication, no charge & discharge, no connection to the power grid.
- Power off via the BMS host computer.

 **NOTICE**

Before switch the battery to sleep mode, make sure that there is no external power (such as power grid) connect to the battery, otherwise it cant achieve to sleep.

Active mode

In case of that the battery is in the sleep mode, it will turn to active mode when achieved one of below conditions:

- Connect to the charger, and the charge voltage is exceed 48V.
- Press the reset button for 3~6s and then release it.
- RS232 communication is activated

4.4 Protection function

Table 4-8 LED Flash Definitions

Items	Description	Remark
Charge end COVP POVP	The BMS will stop charging if any cell or PACK voltage reach the protection value and it will be auto-released only when both Pack and cell voltage back to the release voltage range or there is an efficient discharge current.	The efficient discharge current value is $\geq 0.5A$
Discharge end CUVP PUVP	The BMS will stop discharging if any cell or PACK voltage is under the protection value and it will be released only when all the cell voltage back to the release voltage range or there is efficient charge current.	Able to automatic recovery. Please charge timely, otherwise it may be in Low-power mode to be over-discharged and damage battery.
CHTP DHTP	The BMS will stop charging or discharging or both if any cell/environment/MOS temperature is beyond the range.	Automatic recovery when the temperature fall to the release value.
CLTP DLTP	The BMS will stop charging or discharging or both if any cell/environment/MOS temperature is under the range.	Automatic recovery when the temperature rises to the release value.
COCP	The BMS will stop charging when the charging current is over the protection value. And it will released from the protection when the system delays time is met.	Automatic recovery. If locked after three consecutive times, manual intervention is required.
DOCP	The BMS will stop discharging when the discharging current is higher than the protection value. And it will release from the protection when the system delays time is met	Automatic recovery. If locked after three consecutive times, manual intervention is required.
SCP Reversed protection	The BMS will stop charging when detected short circuit or reversed protection.	Charge to release. Manual press reset.
Temperature, Voltage, Current sensor failure	Turn to the failure mode, manual intervention is required to no charging and discharging.	Manual intervention.
Sleep mode	After reaching a certain condition, BMS will turn to sleep mode to reduce BMS consumption	Charge, press reset or restart to activate.

 **CAUTION**

Please recharge the battery via MPPT/grid/generator or other energy source within 24h if the battery is over discharged, otherwise, it may be damaged.

 **NOTICE**

Manually short-circuit and reverse the battery will void the warranty.

5. Installation

5.1 Preparation

5.1.1 Safety Compliance

The system installation must be completed by qualified person(s), During the whole installation process, please strictly follow the local safety regulations and related operating procedures.

5.1.2 Environment

The operating environment shall meet the following requirements:

Table 5-1 Operating environment requirements

Items	Description
Working temperature	0°C ~50°C (maximum charging range) -20°C -55°C (maximum discharging range) 15°C -30°C (optimal temperature)
Relative humidity	5%~95%, No condensation
Altitude	<4000m
Safety requirement	<ul style="list-style-type: none"> • Do not expose the battery to direct sunlight, rain and snow. • Do not place the battery within children/pet touchable area. • Do not place the battery near heat source and flammable material • Do not drop, deform, impact, cut or spearing with a sharp object. • Do not put heavy things on battery. • Do not disassemble the battery without Manufacturer's permission. • No conductive dust and water or other liquid to contact battery. • Follow the emergency measures if there is water invasion or electrolyte and gas leakage. • Contact your supplier within 24 hours if any product failure happens.

5.1.3 Tools

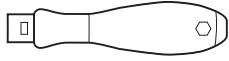

Torque screwdriver

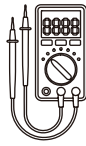

Multi-meter

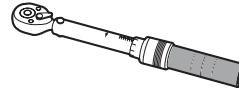

Torque wrench

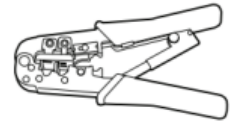

Cable crimper

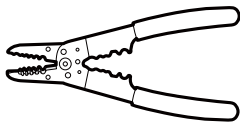

Wire stripper

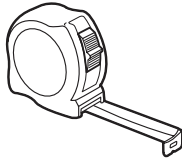

Tape measure



Flat-head screwdriver

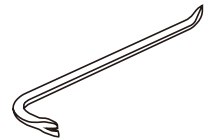

Crowbar



Phillips-screwdriver bit



Phillips-head screwdriver

5.2 Inspection

- Please load and unload it in accordance with the specified requirements to avoid the sun and rain when you receive the equipment.
- Please check and confirm the goods (such as quantity, appearance, etc.) according to the "scope of delivery " before unpacking.
- Do light take and put during unpacking process to protect the surface coating of the object.
- Please record and feedback to the manufacturer if the inner packing is damaged after unpacking.

5.3 Installation

 Qualified person

5.3.1 Prepare

- Please check again the following conditions or equipment whether meet the requirements before installation:
- Check if there's enough space for installation.
- Check whether the power cable pair(s) used meets the maximum current requirement for operation.
- Check whether the overall layout of power supply equipment and batteries at the construction site is reasonable.
- Check whether the installer is wearing anti-static wristband.
- Check whether there're two people on the construction site for installation work.
- Check if there's potential risks at location of installation site, e.g. flooding, sun exposure, corrosion, and salt spray.

5.3.2 space requirement

The minimum installation distance between the battery PACKs is as below:

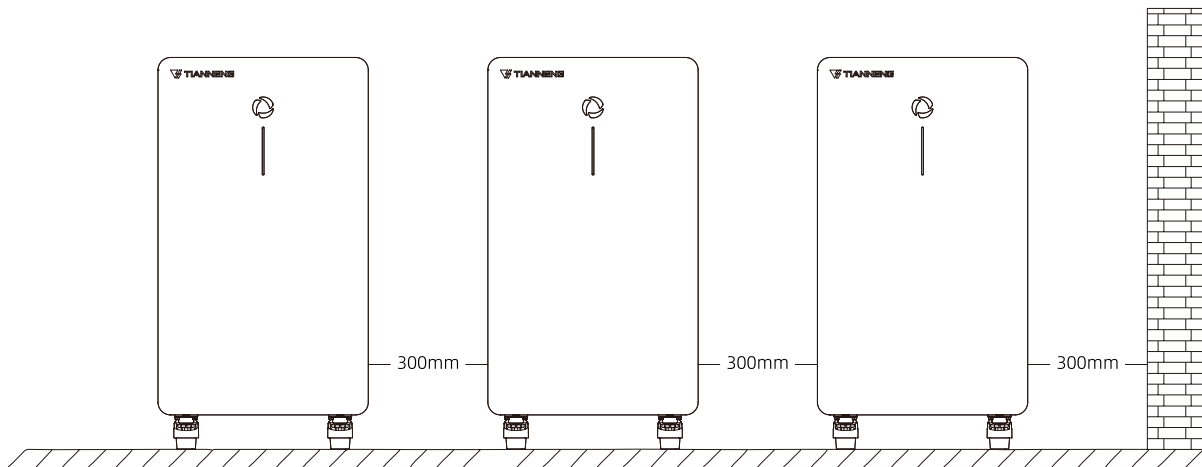

Diagram 5-1 Battery Installation Distance Diagram

5.3.3 Procedures

CAUTION

- Injuries may result if the product is lifted incorrectly or dropped while being transported or mounted. Wear suitable personal protective equipment for all work on the product.
- Ensure that there are no cable or pipe laid in the wall which could be damaged when drilling holes.

- ① Use a crowbar to open the wooden box, then use straps or manually stand the batteries upright.
- ② Adjust the leveling caster to result the wheel available.
- ③ Move the battery to a reasonable installation location
- ④ Adjust the leveling caster to result leveling foot contact the floor and adjust the leveling foot to ensure that the battery is vertical and stable.
- ⑤ Open the dust cover and finish the power and communication cable connection.

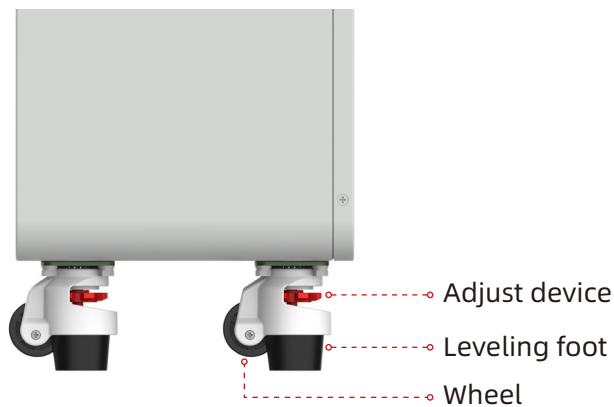

6. Electrical connection and commissioning

 Qualified person

6.1 Prepare

- Ensure all the battery is in OFF mode, check and confirm the installation is tightened and stable.
- Check the number and specification of cable kit accessories are correct according to the Scope of delivery item, if you are making cable yourself, please follow manufacturer's requirements.
- Switch on all battery individually before wiring, check whether there is any alarm/ protection information, if yes, turns to troubleshooting. Then switch off all batteries.

6.2 Grounding cable connection

- Take out the grounding screw on the battery panel and get the cable conductor through it.
- Fix them together with a screwdriver and tighten it.
- Connect the grounding cable with PE busbar or nearby grounding point.

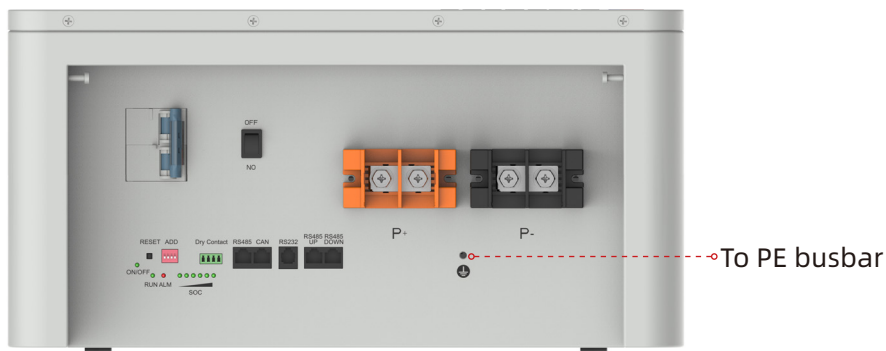

6.3 Connection block diagram

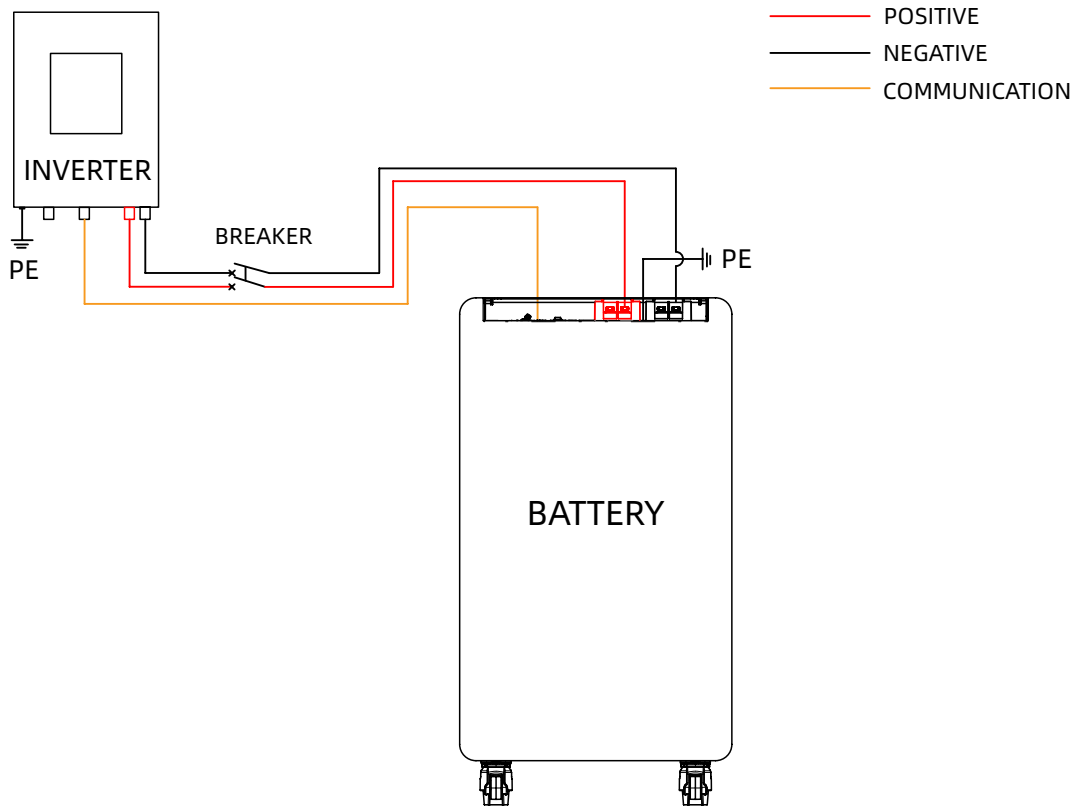

Diagram 6-2 Single use application wiring diagram

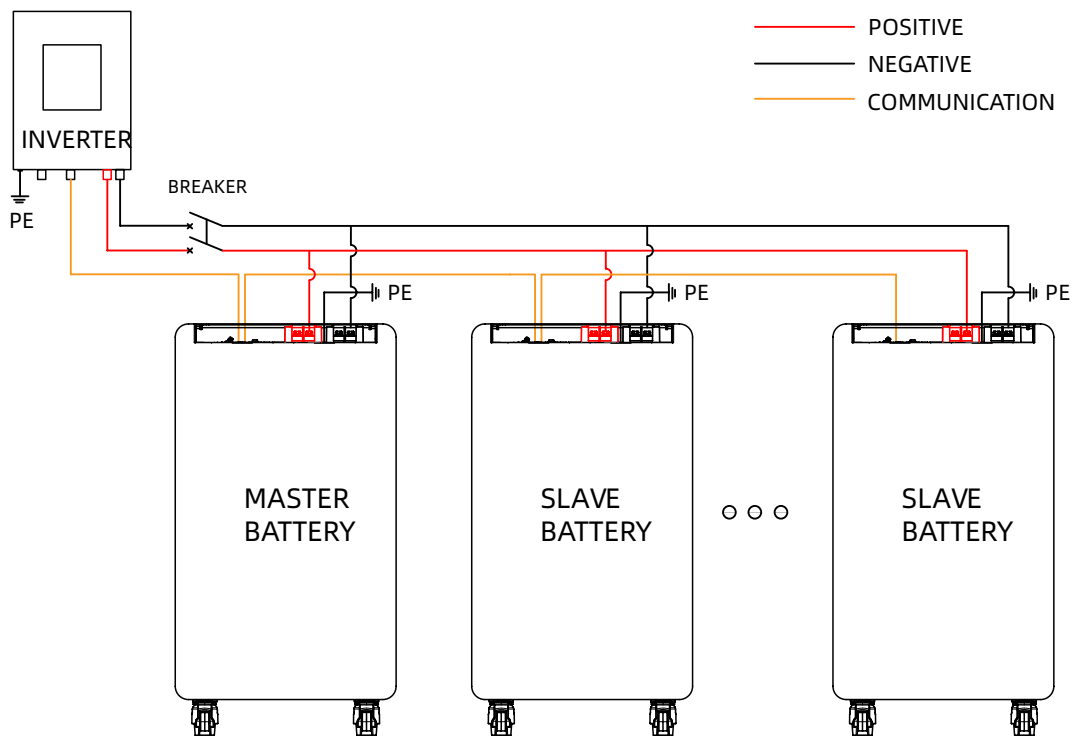

Diagram 6-3 Battery parallel use application wiring diagram

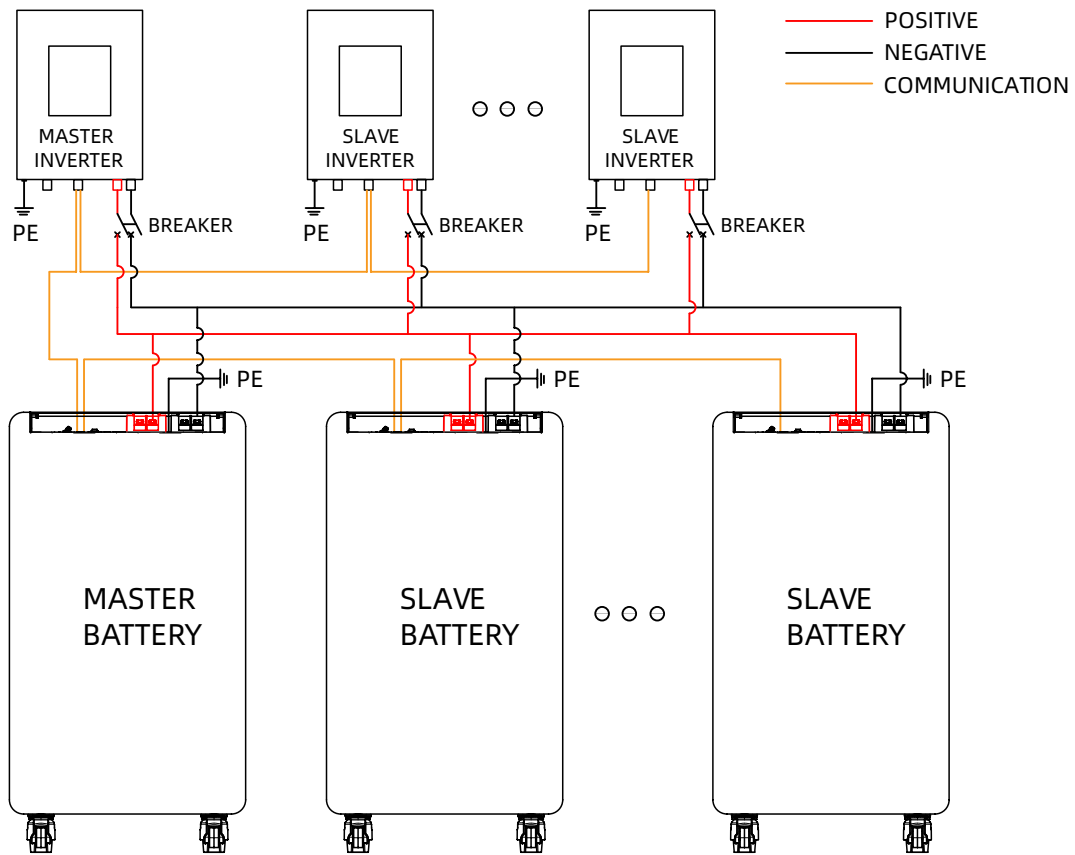

Diagram 6-4 Battery and Inverter Parallel Use Application Wiring Diagram

NOTICE

- If the battery system total output/input current $\leq 200A$, the power cable between battery modules which in parallel allowed to connect to the P+P- terminal directly, otherwise need connect the power cable to a combiner busbar.
- In case of the batteries connect to the busbar, The power cables must have the equal length.

6.4 Communication cable connection

6.4.1 Single use application

Connect the communication cable to the inverter or charger according to 5.6 requirement.

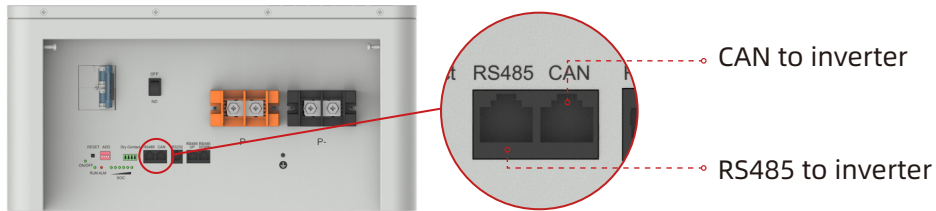

Diagram 6-5 Single Use Communication Cable Wiring Diagram

6.4.2 Used in parallel

- Used RJ45 communication cable to connect batteries via RS485 UP/RS485 DOWN port, the battery RS485 UP connect to the upper battery RS485 DOWN.
- Set the batteries communication address via DIP, the master battery (the one which connect to the inverter) set "1", and other slave batteries set in sequence from 2 to 16.
- Connect the communication cable to the inverter or charger according to 6.6 requirement.

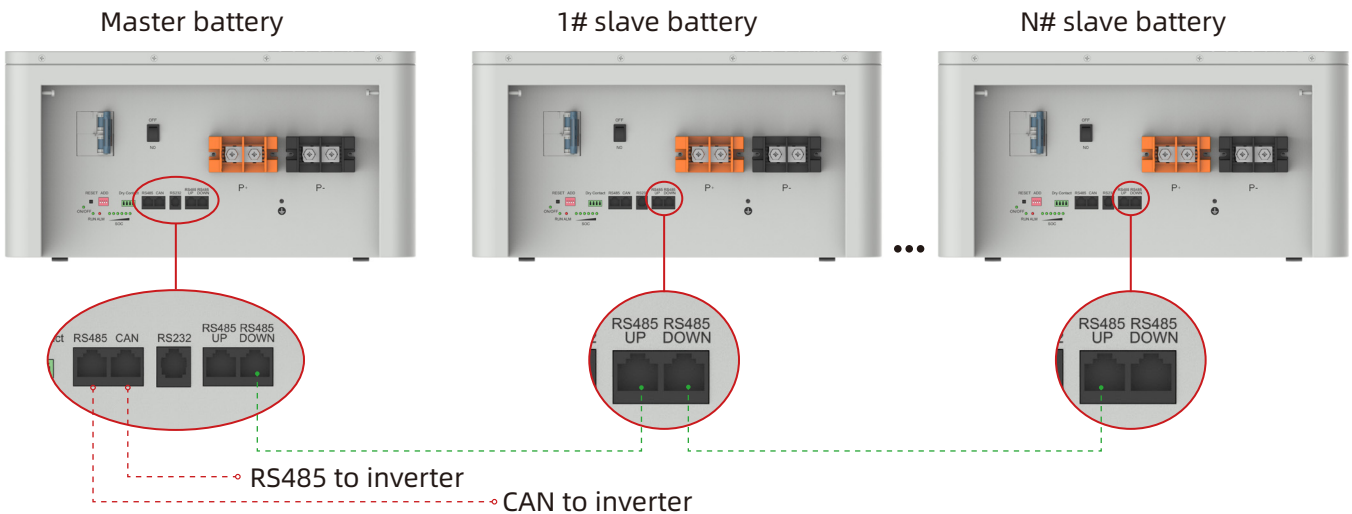

Diagram 6-6 Parallel Use Communication Cable Wiring Diagram

6.5 DC power cable connection

6.5.1 Single use

Connect the power cable to the inverter or charger power terminal according to 5.6 requirement

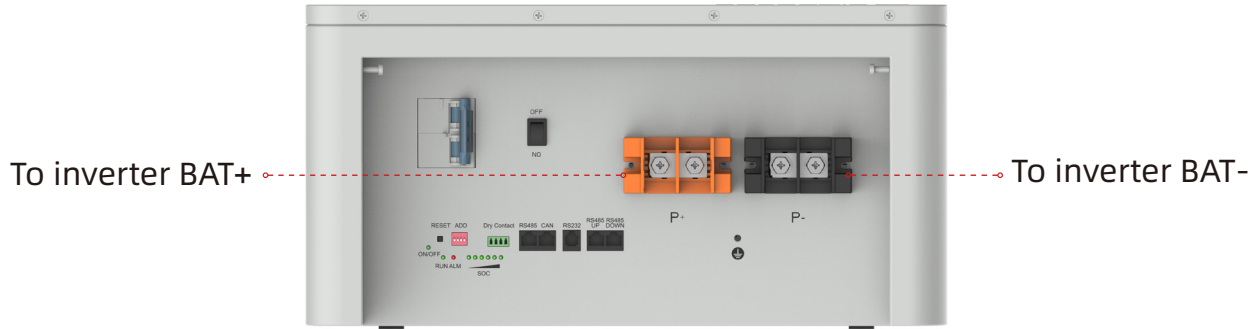

Diagram 6-7 Single Use Communication Cable Wiring Diagram

6.5.2 Used in parallel

Connect the positive cable to the positive combiner busbar, and connect negative cable to the negative busbar too, connect the grounding cable of batteries to the PE busbar or nearby grounding point. If the battery system total output/input current $\leq 200A$, the power cable could connect to the battery P+/P- terminal directly.

Connect the inverter battery input power cable to the combiner busbar according to 5.6 requirement.

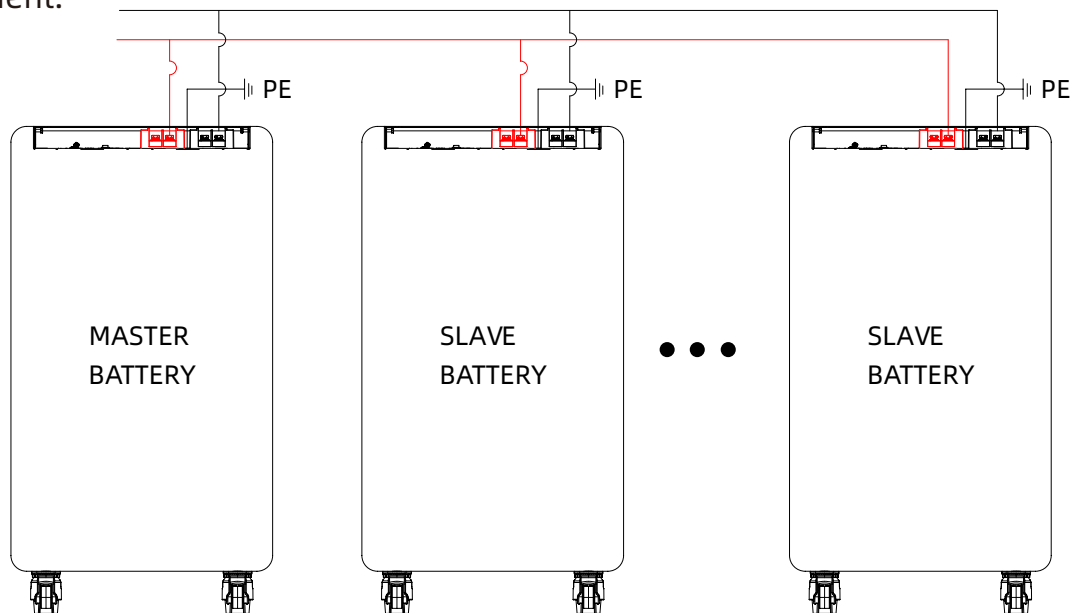

Diagram 6-8 Batteries in parallel power cable wiring diagram

 **NOTICE**

In case of the batteries connect to the busbar, The power cables must have the equal length.

6.6 Connecting with inverter

 **CAUTION**

Confirm inverter AC input and PV input is disconnected before wiring connection, the grounding cable is connected correctly, and the DC/ signal switch of inverter/ charger is in off status.

- Connecting battery (if used in parallel, connect the master battery) RS485/CAN port with inverter CAN or RS485 communication port via inverter communication cable.
- Connecting battery positive output (P +) with inverter battery INPUT(BAT+), negative output (P-)with inverter battery INPUT (BAT-), an external disconnection breaker between battery system and inverter is recommended, choose the corresponding power cable and wiring them correctly.
- If the battery and inverter used in parallel, please Diagram 6-3 or 6-4 to connect the power and communication cables between batteries first, then connect the power and communication cables between inverters, then connect the communication cable between master battery and master inverter, at last connect the power cable.
- Considering system stability, it is recommended to configure the inverter capacity with battery energy in maximum 1:2 proportion, for instance, single LMS-16K-A battery configure maximum 8KW inverter, 2 pcs LMS-16K-A batteries used in parallel configure maximum 16KW inverter.

 **NOTICE**

- *Choose the suitable disconnection breaker considering the inverter power/current, rated voltage, tripping characteristic etc.*
- *The maximum communication cable length is required to be less than 15m between inverter/charge and battery.*
- *The maximum power cable length is suggested to be less than 10m between inverter/charge and battery.*

6.7 Commissioning

CAUTION

- The power cable connection between the batteries and the inverter(s) is switched off.
- The inverter must be correctly mounted.
- All power and communication cables must be correctly connected.

- Switch on the “ON/OFF” button of the battery (s) , check the LED indicator is indicate correctly depend on “Table 4-6 LED Indicator Lighting Definitions” contents, and make sure that there are no alarms.
- Turn on the breaker between the inverter and battery if there is any.
- Connect a computer via RS232 port of the battery (master battery) , running the BMS host computer, and select the right communication protocol in “system setting–inverter protocol setting” , and check the data is indicate correctly and no alarm.

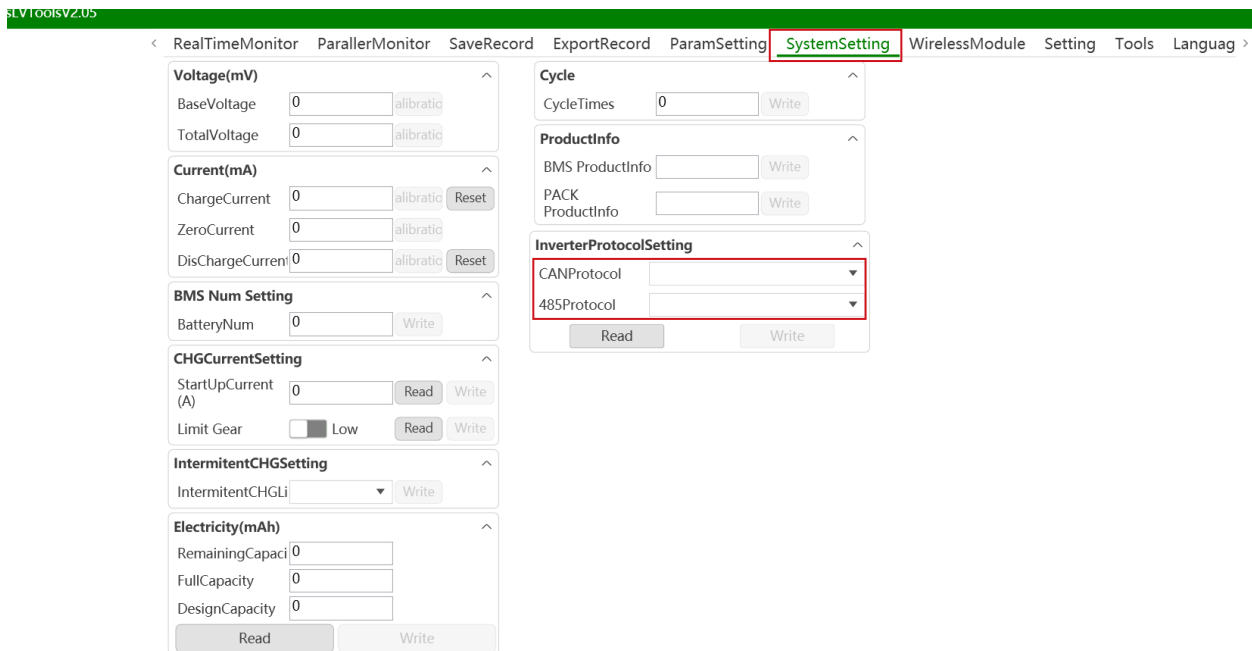

The screenshot shows the 'SystemSetting' menu in the BMS software. The 'InverterProtocolSetting' section is highlighted with a red box, showing two dropdown menus: 'CANProtocol' and '485Protocol'. Below these menus are 'Read' and 'Write' buttons. Other sections visible include 'Voltage(mV)', 'Current(mA)', 'BMS Num Setting', 'CHGCurrentSetting', 'IntermitentCHGSetting', and 'Electricity(mAh)'.

- Finish the setting on inverter/charger or any other control devices, if everything is correct, you are ready to use the system.

Table 6-1 battery setting parameters in inverter

No.	Inverter setting parameters	Detail
1	Absorption voltage	56.0V
2	Float voltage	54.6V
3	Low SOC standby voltage (Grid-tied)	≥ 50V
4	Release voltage(Grid-tied)	52V
5	Low SOC limit (Grid-tied)	10/20% (depend on the DOD setting)
6	Low SOC cut-off (Off-grid)	5%
7	Low Voltage cut-off	48.0V (depend on the DOD setting)
8	Rated charging current limited value	157A
9	Rated discharging current limited value	157A
10	Max. charging current limited value	200A
11	Max. discharging current limited value	200A
12	Force charge/ Activate	Enable

 **NOTICE**

For more information to connect with different inverter/charger, please contact your supplier for technical support.

 **CAUTION**

If your system is a back-up or off-grid system, make sure your configuration can cover the worst situation to avoid battery to be over-discharged.

6.8 Switch off battery

- Switch off the inverter.
- Switch off the breaker between the inverter and battery if there is any.
- Switch off all batteries via ON/OFF button.

7. Troubleshooting and FAQ

7.1 Troubleshooting

Table 7-1 Troubleshooting List

Items	Items	Detail
Unable to start	Power on battery and press RESET 6s to observe whether the battery can be started. Charge the battery via a charger or inverter with 54~57.6V output and observe whether it can be started.	
Unable to charge	Check whether the cable connection between the battery and inverter/charger is correct. Check whether the inverter/charger setting is correct. Check whether the battery is in over voltage protection status, if yes, try to discharge the battery.	
Unable to discharge	Check whether the cable connection between the battery and the inverter/charger is correct Check whether the battery occurs short circuit, reverse connection, pre-charge failure during connection inverter etc. Check whether the battery is in low voltage protection status, if yes, try to charge the battery.	If the abnormal status still alive after above steps, please contact your supplier.
High/Low temperature	Stop the battery system for a while, check whether the installation location temperature meets the requirement. Avoid continuous full charging and discharging.	If there is any other situation(s) excluding in this table, turn off the fault battery, contact your supplier.
High current	Stop the battery system for a while, check whether the installation location temperature meets the requirement. Avoid continuous full charging and discharging.	
ALM always on	Check the fault information on the inverter APP or display if possible. Ask your supplier to offer BMS monitoring software to locate the reason and back to them for solution.	
Communication fail	Check the fault information on the inverter APP or display if possible. Ask your supplier to offer BMS monitoring software to locate the reason and back to them for solution.	

7.2 FAQ

① Q2: 'High voltage' and 'cell unbalance' warning and alarm in rare cases, does it mean battery is damaged?

No. This is not unusual and happened on new batteries that are not balanced yet, please lower the maximum charge voltage (54.6V) and float the battery via grid or generator. If not solved, please contact your supplier.

② Q3: When having multiple batteries in parallel connection, the battery on the end can't be fully charged.

Pay attention to your wiring diagram, please always follow the manual wiring advises and choose proper cable size and pair.

③ Q4: The current is 0A when connecting with a very small load at the situation that having multiple batteries in parallel connection, how to solve it?

Each BMS has a threshold current of 0.5A (~25W) before it begins to report, this leads to the inaccurate display of the current.

④ Q5: SOC is not accurate or suddenly jumps to 100% during charging.

This mostly happened in off-grid applications on batteries that have not been calibrated SOC for a long time or situations that are similar to Q4 that with inverter in standby mode or a small DC load or store the battery for a long time, we suggest fully charging at once the batteries per month refer to Q1.

⑤ Q7: Inverter pulling power from Grid to charge batteries in self-consumption mode.

When reached certain conditions such as low state of charge etc., battery will send charge request to ask inverter to charge the batteries, to avoid this, please set the DOD as manual suggested.

8. Transportation and Storage

- Do not violently shake, impact or squeeze, and prevent sun and rain during transportation.
- Do light take and put and strictly prevent falling, rolling, and heavy pressure during loading and unloading.
- The battery should be placed in a dry, clean, dark, and well-ventilated indoor environment for long-term storage, and the recommended storage temperature range is 15~30°C .
- No harmful gases, flammable and explosive products and corrosive chemical substances in the storage location.
- The batteries should be stored and transported in close to 50% SOC, do not store over 80%SOC for long time.
- If storage or unused for a long time, the battery needs to be charged every 6 months.

NOTICE

- *Charge the UVP battery within 2 days when the temperature is above 25° C.*
- *Charge the UVP battery within 7 days when the temperature is below 25° C.*

9. Disposal of battery

Disposal of battery must comply with the local applicable disposal regulations for electronic waste and used batteries, please review your local Battery recycling or management regulations or contact your supplier or TIANNENG for more information.

Appendix I

Inverter Communication Protocol List

RS485 protocol

001-PYLON RS485LVV3.5-2019.12.23(派能)(默认)
002-GrowattRS485 V2.01-2019.02.13(古瑞瓦特)
003-Voltronic RS485InverterV1.5-2022.01.18(日月元)
012-LuxpowertekRS4852018.05.21(鹏城)
012-LuxpowertekRS485Inverter0.1(鹏城)
012-LuxpowertekRS485Inverter0,3-2020.07.06(鹏城)
036-WOW RS485 Modbus V1.3-2017.06.27(硕日)

CAN protocol

REV0 series low voltage battery BMS communication protocol(V1.04)(迈格瑞能)
001-PYLON CANInverter EMS(派能)
001-PYLON CAN LV V2.0.2-2021.06.15(派能)002-Growatt CANLVV1.05-2019.08.28(古瑞瓦特)
002-Growatt CANLVV1.09-2020.10.22(古瑞瓦特)
007-GoodWe CANInverterLVV1.7-2020.02.28(固德威)
010-Victron CAN 2021.01.07(维克托)
012-LuxpowertekCANV1.0-2020.02.11(鹏城)
013-Sorotec CANInverter V1.0(索瑞德)
014-GINLONG CANLVV1.0-2019.12.28(锦浪)
015-Schneider CAN V2.0(施耐德)
017-SMA CAN V2.0(艾思玛)
028-Senergy CANV1.1-2022.05.10(盛能杰)
030-MUST CANPV1800F(美世乐)
030-MUST CANV2.0.2-2021.06.02(美世乐)
033-TBB CAN V1.05-2021.04.20(TBB)035-STUDERCANV1.02-2018.06.14(特能创新)
PCS-CANBUS Protocol V3.2(德业)



Zhejiang tianneng energy storage technology development Co., Ltd

Address: No.18 Baoqiao Road, Changxing Country, Huzhou, Zhejiang Province, China

Tel: +86-400-8788-188

Web: www.tianneng.com